

Saffire™ LX-P

SMART RFID Exit Device Compatible Lock



Features

- Expand your access control as your multihousing community grows
- Complements panic devices and electronic access
- Available with third-party integrations to create a modern living experience
- RFID credentials are easy-to-use and hard-to-lose
- Eliminates cost and hassle of managing keys
- Designed to support use with panic devices
- Ideal for new construction projects or retrofits
- Suitable for small to large-scale multihousing properties
- Commonly used on perimeter entry points in conjunction with the full Saffire product line up to deliver a property wide electronic access control solution

Overview

Saffire LX-P Smart RFID Lock features RFID technology in a contemporary design and provides support for use with exit trim devices. Using Saffire LX-P, multihousing properties now have the option of issuing mobile, fob, wristband or card credentials for added convenience. Easy-to-use, flexible and secure, Saffire LX series offers a suite of smart solutions that combine high-performance with clean aesthetics.

Convenient Mobile Access

Equipped with Bluetooth Low Energy (BLE) technology, Saffire LX-P gives mobile-minded residents the convenience of using

a smart device to simplify access throughout the property. Our state-of-the-art key delivery platform securely issues and authenticates mobile credentials through BlueSky, dormakaba's mobile access app.

Intuitive Access Management Software

The Saffire LX-P is managed by Community™, dormakaba's access management software. Community empowers property managers to intuitively manage access to residences, amenities, common areas and perimeter from a single platform, improving security and operational efficiency. Community can issue both RFID and mobile credentials seamlessly and within minutes.

Smart and secure solutions:

- Maintains lock programming and audit records
- Staff monitoring – RFID keycard audits
- Tamperproof design
- No touring – Update access without visiting lock
- Operates with a completely sealed, high performance contactless reader
- Battery life up to 2 years under normal operation
- Low battery indicator for preventative maintenance

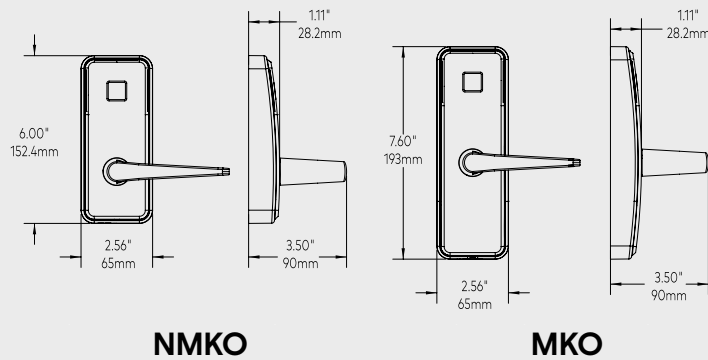

Mechanical Features

Description	Saffire LX-P Panic Device
Handing	Field reversible
Lever	Essen, Von and Long Return, custom lever options available, consult with your sales representative Satin
Finishes**	chrome, satin brass, ocean front, oil-rubbed bronze, bright chrome, satin nickel and black finishes: black ** dormakaba utilizes PVD (physical vapor deposition) finishes in some instances
Door Thickness	Option 1: 1-3/4" - 2"; Option 2: 2" - 2-1/4"
Locking Options	Designed for compatibility with a wide selection of exit devices (see price book for complete listing) 3
Batteries	AA for up to 2 years. Low battery indicator for preventative maintenance
Concealed key override	Electronic battery backup
Community RX	Lock controller board with Messenger capability

Mobile Access

BLE enabled	BLE enabled. Ready to operate using dormakaba mobile access solutions.
-------------	--

Lock Operation

No Touring	New credentials automatically cancel prior credential when brought to lock
Electronic Key Levels	User defined, customizable key levels & key groups tailored for your community. Individual levels for residents, leasing, maintenance, services and vendors.
Date/time stamp	Real time: date and hours/minutes; automatically adjusts for daylight savings time
Programming & audit trail	Handheld unit incorporating Near Field Communication interface and security features
Lockout mode	Set by authorized key
Credentials accepted	- Mifare Ultralight C: Guest Keys - Mifare DESFire: Guest and Staff Keys (DESFire EV3 2k, DESFire EV2 4k, DESFire EV3 4k, DESFire EV3 8k) - Mifare Plus: Guest Keys (Mifare Plus 1K), Staff Keys (Mifare Plus S 1k, Mifare Plus S 2k, Mifare Plus S 4k) - Mifare Classic: Guest Keys (Mini), Staff (Classic 1k, Classic 4k)
Feedback LED	Light indicators
Diagnostics	Handheld display
Audit memory	Most recent 4,000 events

Certifications

Certification	BHMA A156.25
Fire rating	Meets UL 10C and ULC S-104, on fire door rated up to and including 3 hours
Electronics	Compliant with RE Directive 2014/53/EU for electromagnetic compatibility and FCC part 15 and RSS-247 Industry Canada requirements.
Environmental operating	-31°F to +158°F (-35°C to +70°C), 0% to 90% non-condensing humidity at 86°F (30°C) Meets IP54
Warranty	Two years

Exit Device Operators

dormakaba offers a series of exit device hardware that is compatible with mechanical and electrical applications. This hardware is manufactured for the most demanding access/egress applications.



Rim Exit Device

The Dorma 9300 series is a single-point rim latch with a modern touch bar design.

Vertical Rod Exit Device

The Dorma 9400 series is a surface-mounted vertical rod exit device with a modern touch bar design.

Hand	Non-handed
Stock	36" door width (standard); 48" door width available at an upcharge
Door types	Wood, hollow metal, fiberglass, or aluminum
Door requirements	Fits standard 1 3/4" - 2 1/4" doors
Mounting height	40" above finished floor
Stile width	4 5/8" with standard 99 strike 4 1/8" with optional 98 strike
Latch bolts	Stainless steel dead-locking; Pullman-type top latch
Finishes**	605 bright brass; 606 satin brass; 611 bright bronze; 612 satin bronze; 613 oxidized satin; 619 satin nickel; 693 black; 625 bright chrome; 626 satin chrome; 629 bright stainless; 630 satin stainless

**Check availability of finishes for devices and corresponding locks before ordering. Other powder-coated finish options available.

Other panic bar options available, for details, contact your dormakaba representative.

Any questions? We would be happy to advise you.

Contact us at: 1 800 849 8324